

## 2 Burner Gas Drop in BBQ

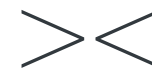

### KEY FEATURES

- High intensity ceramic infrared burners.
- High, even heat distribution over the entire cooking surface.
- Fully controllable burners, performance range from 150° – 350°C.
- Dual cooking surfaces: top and bottom.
- Large cooking area of 3506cm<sup>2</sup>.
- Cook with the lid up or down. Grill oven or rotisserie.
- LPG stanully convertible to natural gas available.



Flush mounted,  
in-bulit BBQ with 2x  
high intensity angled  
infrared burners.



Multipurpose  
outdoor appliance,  
lid up or down.



Flame failure included  
as standard. Suitable  
for non-ventilated  
applications.

# TCS2-IBL

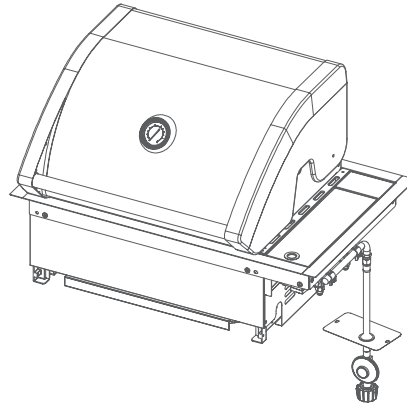
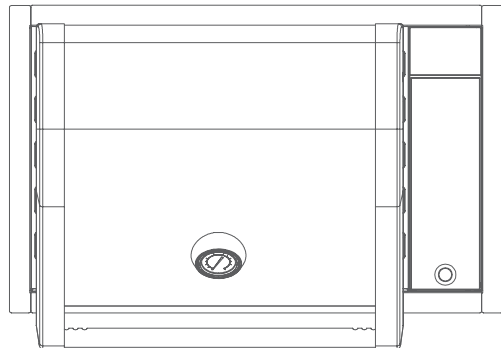
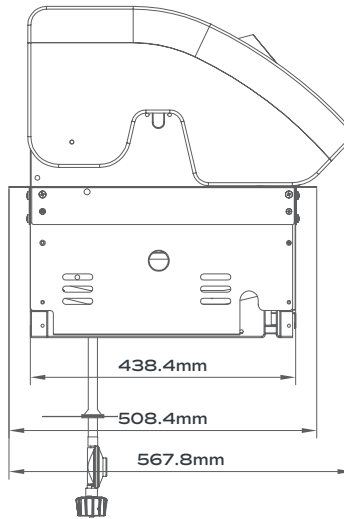
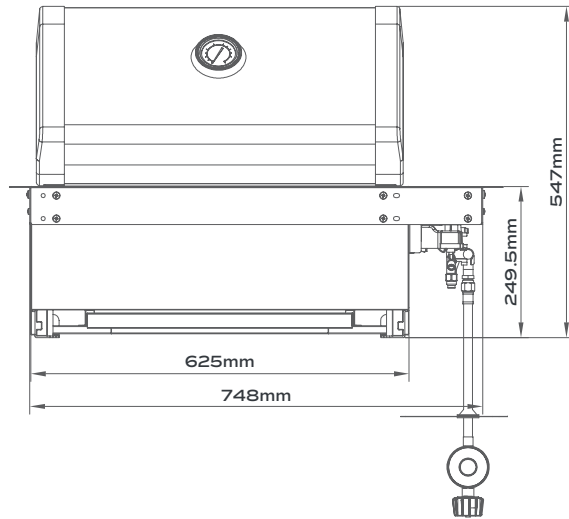

## BBQ

Colour	Silver
Material	304 Stainless Steel Front and Rear Body Panels, Die Cast Aluminium Side and End Panels, 2x Surface Combustion Infrared Burners
Fuel Type	Gas – LPG Standard. Fully Convertible to Natural Gas
Width x Depth x Height	815 x 537 x 541mm
Cooking Area	3556cm <sup>2</sup>
Burner Capacity	13 MJ/h each – Total 26MJ/h
Main Burner	Ceramic Infrared Elements
Grill Material	Ceramic Coated Cast Iron
Ignition Type	Electronic – Battery Operated
Meat Probe	No
Cooking Performance	350°C +

## OVERALL DIMENSIONS

Width x Depth x Height	815 x 537 x 541mm
Weight	34.3kg

## OPTIONAL ACCESSORIES

Hotplate	Yes
Cover	Yes
Rotisserie Kit	Yes

## WARRANTY

Years	2
-------	---