

4 Burner Gas BBQ In-built



KEY FEATURES

- High intensity ceramic infrared burners.
- Robust construction and world-class quality (304 SS with die-cast end panels).
- High, even heat distribution over the entire cooking surface.
- Electronic ignition for simple start-up.
- Significant reduction in flare-ups.
- Easy access front drain tray.
- 2-piece upper-level cooking area provides 60% more cooking space.
- Perfect for all types of cooking: grilling, roasting large meats, low & slow.
- LPG standard. Fully convertible to natural gas available.



Controllable
even heat from
140 - 350°C +



Significant reduction
in flare-ups



High, even heat
distribution over the
entire cooking surface

TCS4FL

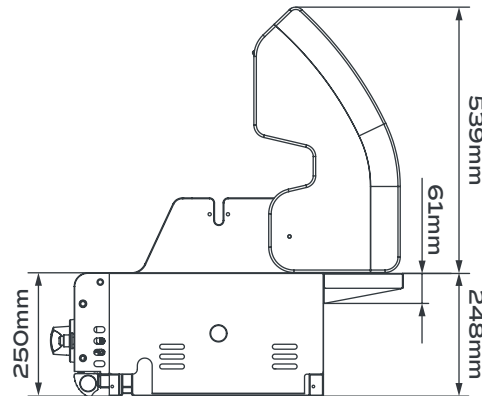
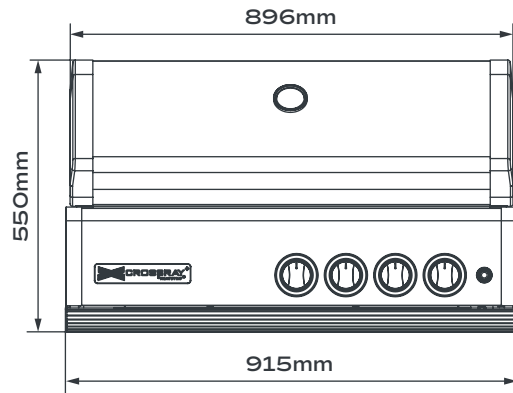
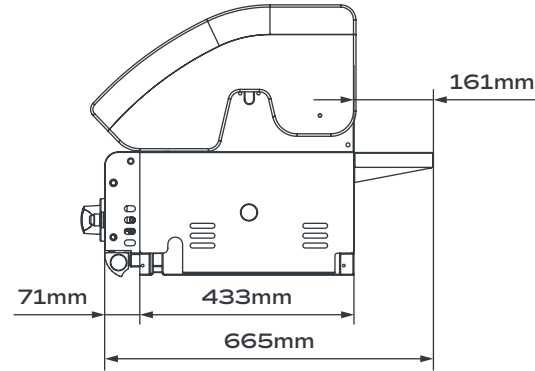
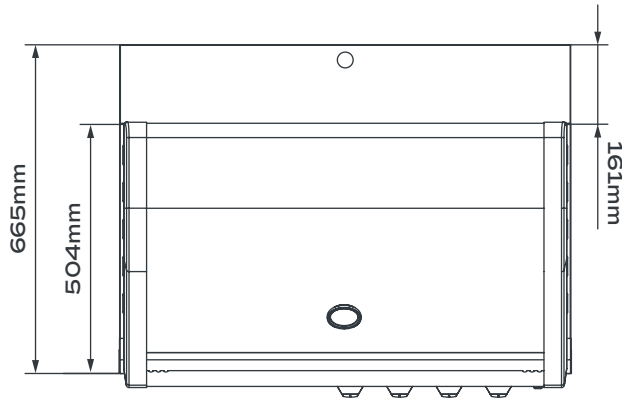

BBQ

Colour	Silver
Fuel Type	Gas – LPG Standard. Fully Convertible to Natural Gas
Width x Depth x Height	915 x 505 x 560mm
Cooking Area	5382cm ²
Burner Capacity	13 MJ/h each – Total 52MJ/h
Main Burner	Ceramic Infrared Elements
Grill Material	Ceramic Coated Cast Iron
Ignition Type	Electronic – Battery Operated
Cooking Performance	350°C +

OPTIONAL ACCESSORIES

Hotplate	Yes
Cover	Yes
Rotisserie Kit	Yes
Roasting Rack	Yes

WARRANTY

Years	2
-------	---